



REQUEST FOR PROPOSAL

Project Title: Cooley Laboratory Renovation
Location: Montana State University

PPA No.: 10-0023
RFP No.: 61
Date: July 23, 2012

To: Dick Anderson Construction
4498 Jackrabbit Lane
Bozeman, MT 59718

Attention: Platisha

From: Cecilia Vaniman, Project Manager
Cooley Lab Renovation
Montana State University

Attention:

In order to expedite the Work and avoid or minimize delays in the Work the following information is requested. Please return a response by: 07/30/2012 Date Sent: 07/23/2012 Date Received:

Proposal Requested:

PROVIDE SPRING MOUNTS @ PENTHOUSE PIPE RISERS (3) LOCATIONS

- Provide Spring Mounts to Penthouse Pipe Risers
1. Clean Steam per schedule attached.
2. Heating Water Supply per schedule attached
3. Heating Water Return per schedule attached

SEE ATTACHED Sheets CM-16

This RFP is for pricing purposes only. The contractor shall not proceed with the scope of work described within until pricing is approved by the owner in writing.

Distribution: [] Owner [] Agency [x] Architect [x] Contractor [] Engineer [] Other

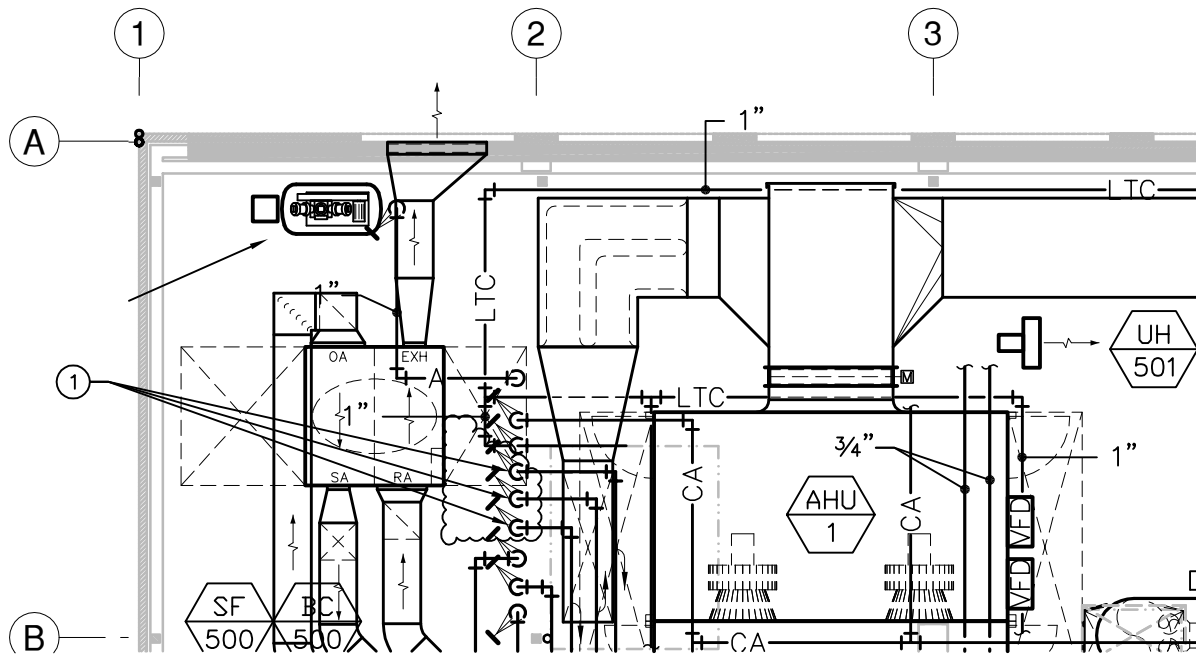

NOTE:
 ① INSTALL SPRING MOUNTS UNDER PIPE SUPPORT CLAMPS IN PENTHOUSE FOR 4" CLEAN STEAM, 4" HEATING WATER SUPPLY AND RETURN (HWS/HWR) PIPE RISERS. SEE DETAIL #2, THIS SHEET.

① PARTIAL PENTHOUSE MECHANICAL PIPING PLAN

1/8"=1'-0"

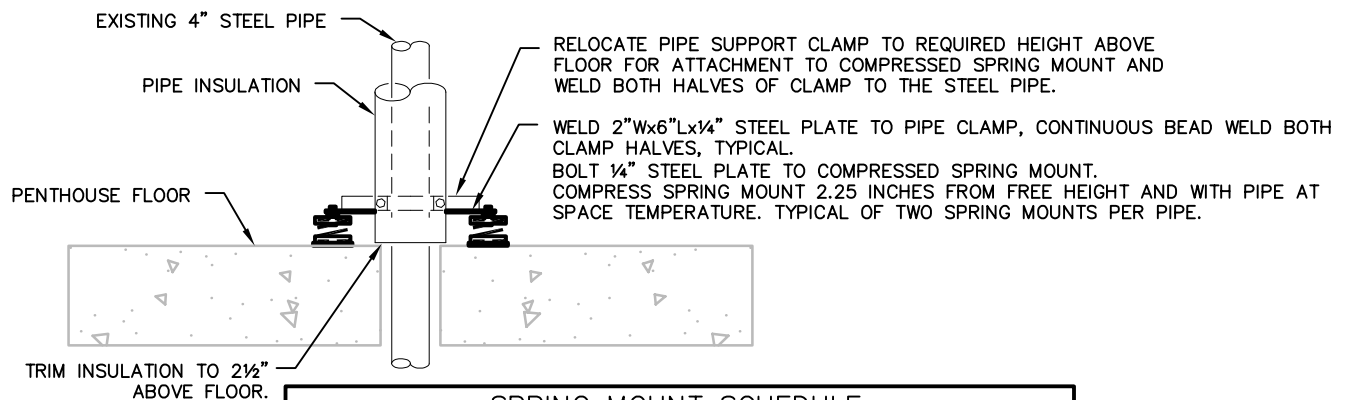

SPRING MOUNT SCHEDULE					
PIPING SYSTEM	MANF'R	MODEL	RATED CAPACITY	RATED DEFLECTION	QUANTITY
CLEAN STEAM (CS)	MASON IND.	SLF103	310 LBS.	2.5"	2
HEATING WATER SUPPLY (HWS)	MASON IND.	SLF104	500 LBS.	2.5"	2
HEATING WATER RETURN (HWR)	MASON IND.	SLF104	500 LBS.	2.5"	2

② PIPE RISER SPRING MOUNT DETAIL

NO SCALE

REFERENCE DETAIL 2/M2.5



524 FIRST AVENUE S
 GREAT FALLS, MT 59401
 PH 406.452.9558
 FX 406.727.9720

2291 W BROADWAY
 SUITE 4
 MISSOULA, MT 59808
 PH 406.721.5936
 FX 406.721.8716

ADD SPRING MOUNTS TO PIPE
 RISERS

MSU-COOLEY LAB RENOVATION
 BOZEMAN,
 MONTANA

ISSUE:

---/---/---	---
---/---/---	---

DATE
 7/19/2012
 PROJECT NUMBER
 100104

DRAWING
 NUMBER
 CM-16
 OF